

**Series 915400 154 MHz Wireless Control System**

**TEST the system before the installation  
ON a bench for proper setup and operation**

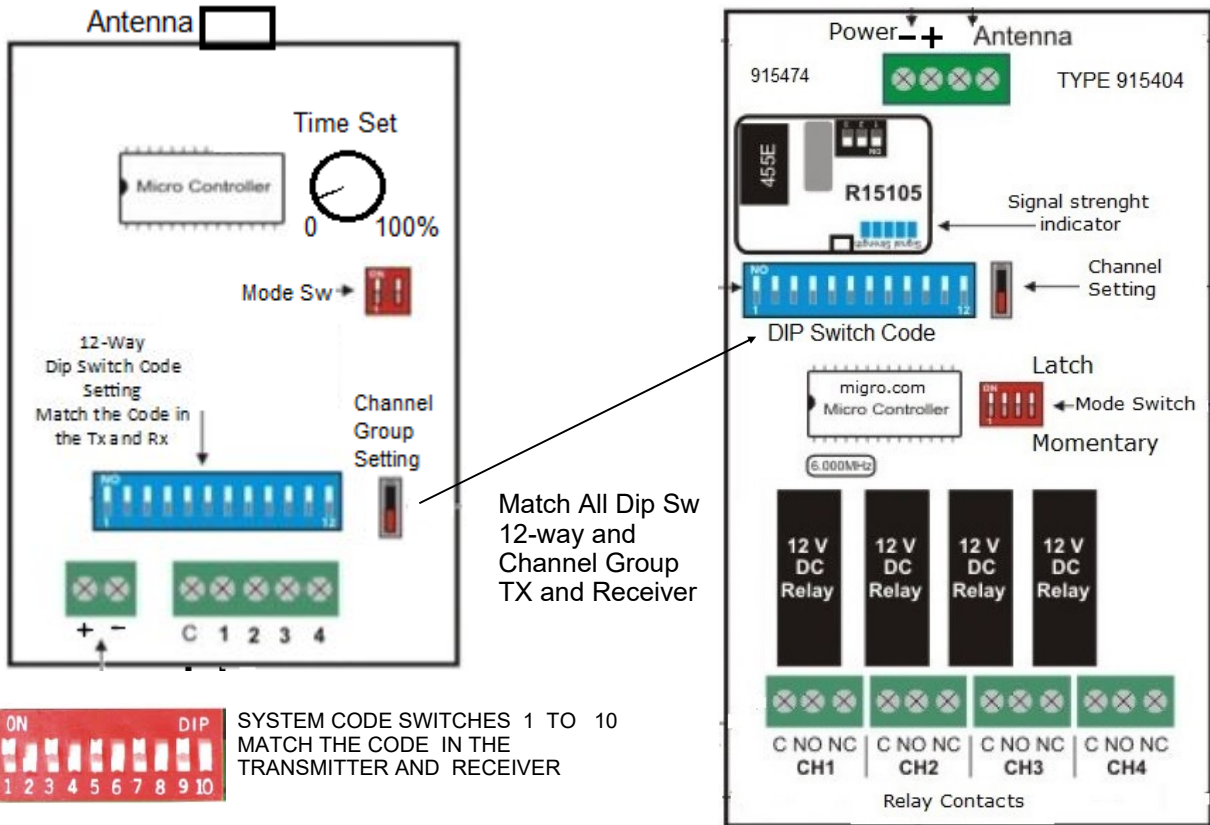

NOTE: Transmitter and receiver antennas shall be mounted facing the same vertical position, (same polarity pattern ) even when there is no line of sight.

**Never operate the transmitter or receiver without the antenna.**

Separate the transmitter and receiver ANTENNAS at least 6 feet ( 2 meter) apart  
Make sure the 12 code DIP switch from the transmitter matches the receiver

1 Connect the Transmitter & Receiver to a power source

2 In the TRANSMITTER terminals (-) & (Ch1) Close momentary INPUT Ch1

At the RECEIVER the Signal Strength level \*\*\*Will light up, To confirm communication Relay energizes. Check contact status with a meter

3 Same procedure for each channel

Relay Contact is SPDT N/O-N/C  
Rated 5 Amp, maximum 250V

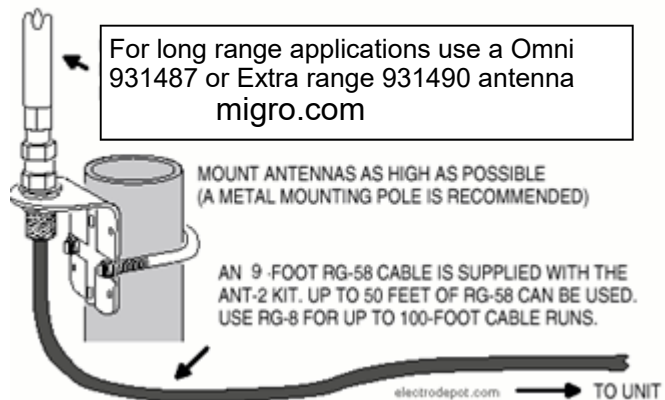

915400 REV 17 migro.com

Warning: Radio control equipment in not to be used in life safety.  
DISCLAIMER: Contact a licensed professional for your project.